



Application Note MTSAP2

Electrical Characterization of OLED's Using Solartron Instrumentation

Introduction

An OLED is a light emitting diode with an organic emissive electro-luminescent layer. The organic layer can be deposited into an active matrix substance in rows and columns to form a matrix of pixels able to emit light of different colours. These devices have attracted much interest from manufacturers of displays since they do not require backlighting (c.f. LCD and Plasma screens). This leads to thinner, lighter displays requiring much less power than LCD's and are therefore of particular relevance for portable display applications such as cell-phones and laptop computers. However, much work still remains to improve the lifetime and stability of the organic materials. The electrical characterization of these materials not only serves to test the stability of the materials but is also used to understand the fundamental mechanisms and processes that contribute to the efficacy of these devices for their applications.

This technical note describes how Solartron electrical characterization products can be used to evaluate the electrical properties of OLED devices. Our discussions will include Current Voltage (I-V) and techniques based upon impedance.

The following sections describe both DC (time domain) and AC (frequency domain) techniques offered by Solartron. Brief examples of the techniques are shown using a single pixel, red OLED device. A brief description and analysis of results is presented.

Characterization of OLED's using DC/Time Domain Techniques

Figure 1 shows the dependence of the I-V characteristics of the OLED device on sweep rate direction and sweep speed. Using a triangle voltage waveform, the voltage was swept at 100 mVs^{-1} (green line) and 300 mV s^{-1} (red line) in the forward bias direction and back. Above 2V, the current is independent of sweep speed and direction. This would correspond with the onset of electro luminescence. Below 2V, the current is strongly dependent upon scan direction and scan speed. This phenomena has been mentioned elsewhere¹ and was attributed to trapped charge.

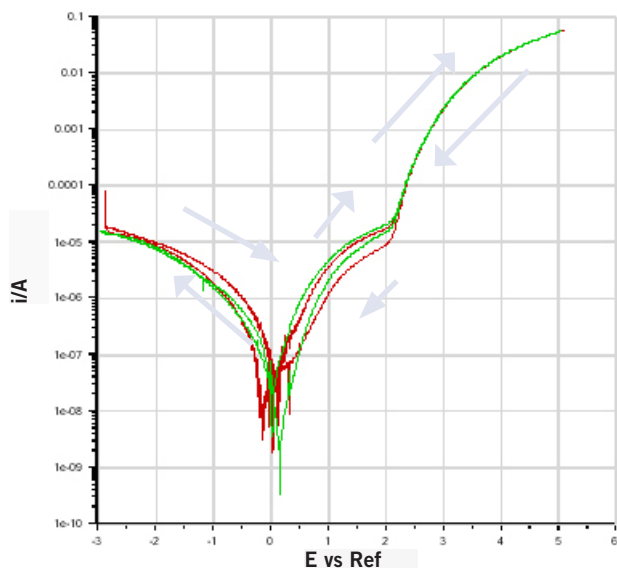

Figure 1: I-V curve of an OLED pixel as a function of scan direction (indicated by arrows) and scan speed. Green line = 100 mV s^{-1} , red line = 300 mV s^{-1} .

A number of features are included in the Solartron software that allow the user to precisely control the applied waveform to the cell (refer to Figure 2). Highlights of these features include;

- Ability to apply linear and triangular voltage waveforms. Some cells exhibit a dependency on the sweep direction and this can be determined by cycling the voltage in both the forward and reverse directions
- Staircase voltage ramps techniques allowing users to look at the step delay response of the cell. The user can define where the current is sampled on the step.
- Pulse potential techniques with ability to define pulse height and pulse width.
- Ability to apply/measure up to $\pm 100 \text{ V DC}$ steps (with hardware option)
- Ability to measure fA's allowing characterization of low leakage currents.
- Range of analytical tools are provided including linear regression analysis.

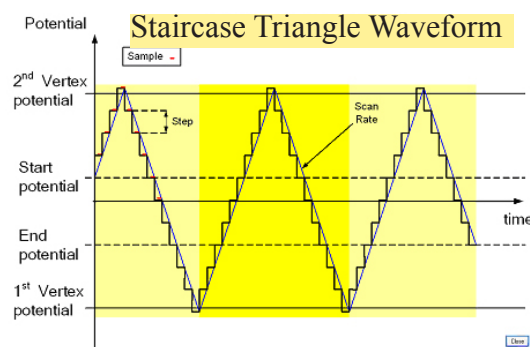
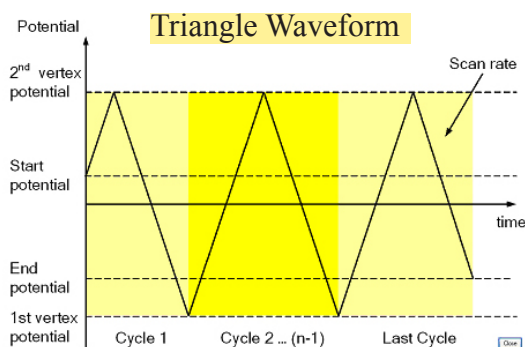

Figure 2a and b Description of a Triangle Voltage Waveforms (linear and staircase) for I-V characterization. Start, 1st vertex, 2nd vertex and end potentials are defined by the end user in the software. Multiple cycles can be used to determine cell stability. Scan rates from 100 mVs^{-1} to 1M Vs^{-1} are available with data acquisition up to 1 Million samples per second.

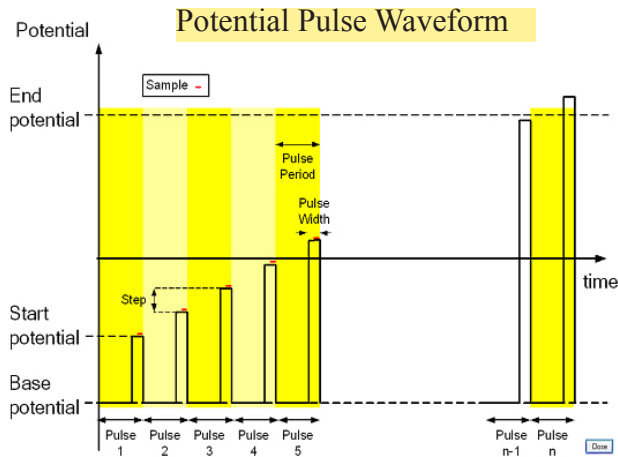

Figure 2c Potential pulse waveform. The user has the ability to define the pulse period, step height and pulse width. Minimum pulse width = 1 μ s

Characterization using Wide Bandwidth Impedance/Admittance spectroscopy

Impedance measurements of OLEDs are performed over a wide range of frequencies which typically cover 1MHz to < 0.001 Hz. This technique has received considerable attention within the academic community. It has helped researchers build equivalent circuits that represent the processes occurring in OLED devices over 7 decades of frequency. The benefits of this technique include;

- Ability to separate processes in the frequency domain including low frequency dispersion and high frequency relaxation.
- All parameters can be determined in a single experiment
- Data can be analysed using equivalent circuit analysis and processes are represented by simple passive circuit elements. Such models are used to quickly determine the processes that limit the performance of the device.

The frequency dependent real and complex capacitance of the device are shown in Figures 3a and b respectively. The results are similar to those observed by Kim et al.² The real capacitance (C') was approximately independent of frequency below 100 kHz. Of perhaps greater interest is the frequency and bias dependent complex capacitances (C'') as shown in Figure 3b.

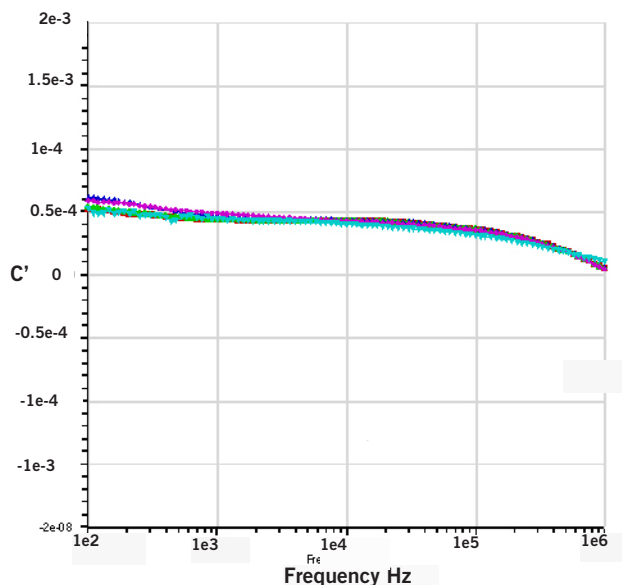

Figure 3a: C' vs. frequency at different bias voltages

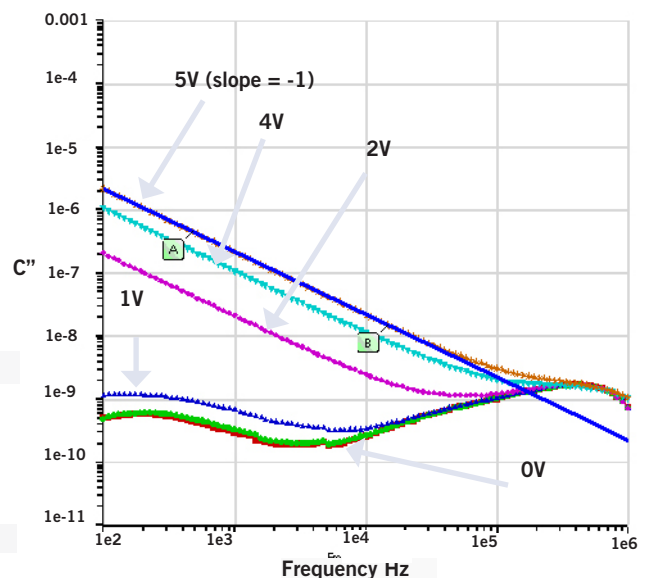

Figure 3b: C'' vs. frequency at different bias voltages (indicated on diagram) with regression slope calculated at $V = 5$ V bias.

According to theory, at high drive voltages and low frequencies, the slope of the complex capacitance plot vs. frequency should be linear with a slope of -1 . This was confirmed using the linear regression analysis tool in the software. This low frequency dispersion is indicative of dc conductivity arising from the continuous hopping of charge carriers over the potential barriers in the network of double potential wells.^{2,4} Furthermore, the complex capacitance increase with bias voltage and has been ascribed to the decrease in parallel resistance (see Figure 5b for equivalent circuit model). This can clearly be seen in the Cole-Cole or Nyquist representation of the impedance of the device (Figure 4). As the drive or bias voltage increased, the diameter of the semicircle decreased in accordance with a reduction in the value of the parallel resistor.

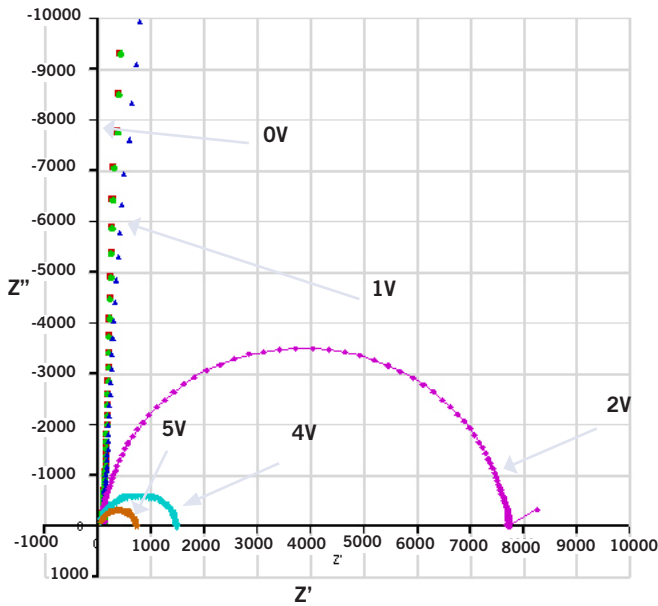

Figure 4: Cole-Cole (Nyquist) plot of the OLED operated under different DC bias voltages (as shown in the diagram)

Several equivalent circuit models have been proposed in the literature that represent the underlying processes within OLED's. Equivalent circuit analysis is offered with Solartron software and a generalised circuit that was created within the software is shown in Figure 5a. A number of simple and distributed elements are available which have been developed to model many physical processes such as Warburg and Gerischer elements. However, for the purposes of this exercise, the model only contains simple resistors and capacitors. The user has the options to model the frequency dependence of the impedance of the circuit in simulation or fitting mode. The simulation mode is a useful tool for the scientist to evaluate if the proposed circuit accurately models the impedance behaviour of the real device. In fitting mode, the values of the components are adjusted to fit the real data. The quality of fitting depends upon the user enter reasonable initial values for R and C.

Reasonable agreement between theory and experiment was achieved. However, the high frequency fitting deviated from the model and suggests a parallel mechanism in this region. Therefore, further refinement of the model is required.

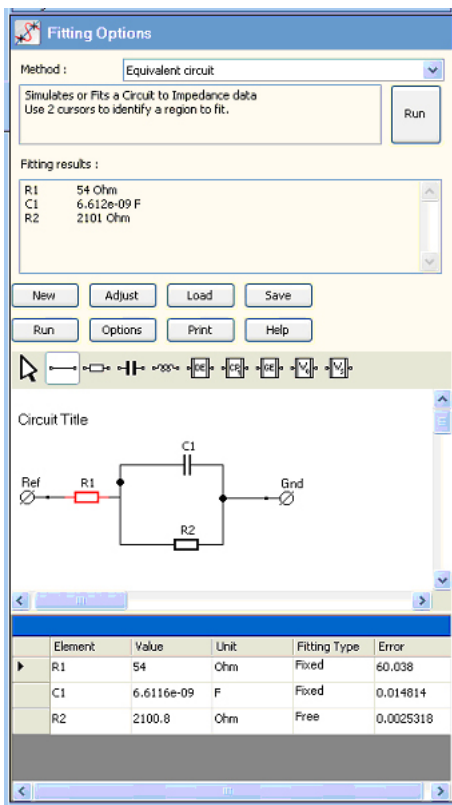
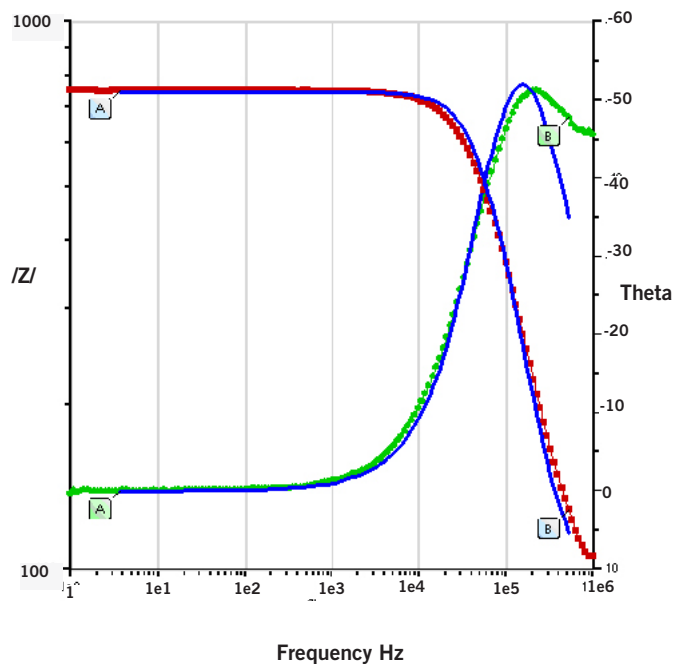

Figure 5b: Comparison between the theoretical impedance magnitude and phase response of the circuit shown in Figure 4a (blue line) vs. the real cell response (red (magnitude) and green lines (phase)). There is reasonable agreement between theory and experiment.

Figure 5a: Equivalent Circuit Modeling tool. Elements can be selected from a drag and drop menu. The circuit shown in this figure was used to model the impedance response of the OLED from 200 kHz to 100 Hz.



There are a number of alternative methods of presenting the impedance data which are supported in Solartron software including, Bode (Impedance, Phase vs. Frequency), complex capacitance and permittivity vs. Frequency, AC voltage and AC current vs. frequency. The use of these methods of data presentation are presented elsewhere in the literature but all have been shown to be useful in the development of our understanding of the fundamental electrical properties of the OLED.

Summary of Measurement Capabilities

This section briefly describes the measurement capabilities offered by Solartron. There are a number of instruments available that are suited towards this application area. Table 1 capture the highlights of Solartron measurement ranges and the information the techniques provide.

Technique	Parameters	Voltage Range	Current Range	Frequency Range
I-V (linear, staircase, pulse, differential pulse)	Hysteresis,	1 μ V resolution to kV (with external amplifiers)	± 0.15 fA resolution to 25 A	NA
C-V (linear or staircase ramp with user defined ac stimulus level)	Complex capacitance, Complex permittivity	1 μ V resolution to kV (with external amplifiers)	± 0.15 fA resolution to 25 A,	1 MHz to 10 μ Hz
Impedance (Single Sine, Multisine FFT)	Phase, Impedance, Permittivity (real and complex), Capacitance (real and complex,	1 μ V resolution to kV (with external amplifiers)	± 0.15 fA resolution to 25 A. 100 $\mu\Omega$ to 100 T Ω	32 MHz to 10 μ Hz

Table 1: Techniques and information obtainable with Solartron Instrumentation. Brief measurement capabilities are included

Conclusion

This technical note described how Solartron instrumentation can be used to characterize the electrical properties of OLED's. Common techniques such as I-V and Impedance/Admittance spectroscopy were shown to yield valuable information regarding the devices under test. The software solutions allow end users to quickly combine DC and AC measurements and control complex experiments without the need to develop their own test programs. The software features are further enhanced with the addition of powerful fitting techniques such as regression analysis and equivalent circuit analysis which are use to model the underlying processes of the materials.

References and Recommended Reading:

- 1) W. Riess et al., Influence of trapped and interfacial charges in organic multilayer light emitting devices, IBM J Res. & Dev. 45 (1) Jan 2001
- 2) S.H. Kim et al., J Applied Phys., 87 (2), 882, 2000
- 3) N.D. Nguyen and M. Schmeits, Phys. Rev.B, 75, 075307, 2007
- 4) A.K. Jonscher, Dielectric Relaxation in Solids, Chelsea Dielectrics Press, London, 1983

Our thanks is given to the Fraunhofer Institute for Photonic Microsystems, Dresden, Germany and the University of Edinburgh, UK, for supplying and testing the OLED devices used in this application note.



Solartron Analytical's Quality System is
approved to
BS EN ISO 9001:1994



FM01709

...part of **AMETEK**® Advanced Measurement Technology

UNIT B1 ARMSTRONG MALL
SOUTHWOOD BUSINESS PARK
FARNBOROUGH, GU14 0NR
UNITED KINGDOM
Phone: +44 (0) 1252 556 800
Fax: +44 (0) 1252 556 899

801 SOUTH ILLINOIS AVENUE
OAK RIDGE
TN 37831-2011
USA
Phone: +1 865 425 1360
Fax: +1 865 425 1334

Visit our website for a complete list of our global offices and authorized agents

solartron.info@ametek.com

www.solartronanalytical.com